

ClearZone Snow Melting Cable

GENERAL PRODUCT INFORMATION

ClearZone snow melting heat cable is a trusted, industry leading cable that is popular in a wide variety of commercial and residential radiant snowmelt applications. The snow melting cable consists of a resistance-heating element insulated with Fluoropolymer (FP) with a high dielectric strength. A metallic sheath is provided to give additional mechanical strength and provide a ground path. A final outer jacket of Polyolefin is provided for corrosion protection and durability.

The convenient design, versatility and rugged construction of ClearZone electric radiant heat cable make it a favorite among homeowners and commercial construction professionals alike.

FEATURES INCLUDE:

- Single point connection
- Twin conductor cable
- Flexible installation
- Durable construction
- Silent, efficient and safe
- Maintenance free
- For use in concrete, asphalt and under pavers
- Power leads are 16.4 feet in length
- CSA listed in U.S. and Canada
- 10-year limited warranty



SPECIFICATIONS

Cable Construction:	Twin conductor
Rated Voltage:	208-600 V (For 277, 600 V, please call.)
Output:	12 W/ft. (40W/m), 24-70W/ft ²
Cold lead:	16.4 feet (5.0 m). Longer cold leads available on request.
Bending Diameter:	Minimum 2 inches (51 mm)
Cable Diameter:	¼ inches (7 mm)
Conductor Insulation:	Fluoropolymer
Metal Sheath:	Copper
Outer Sheath:	Polyolefin
Max. External Jacket Asphalt Temperature:*	220°F (105°C) *[460°F (240°C) for up to 10 minutes]
Max. External Jacket Temperature:	158°F (70°C)
Max. Conductor Insulation Temperature:	302°F (150°C)
Min. Installation Temperature:	5°F (-15°C)

ClearZone Heat Cable Construction

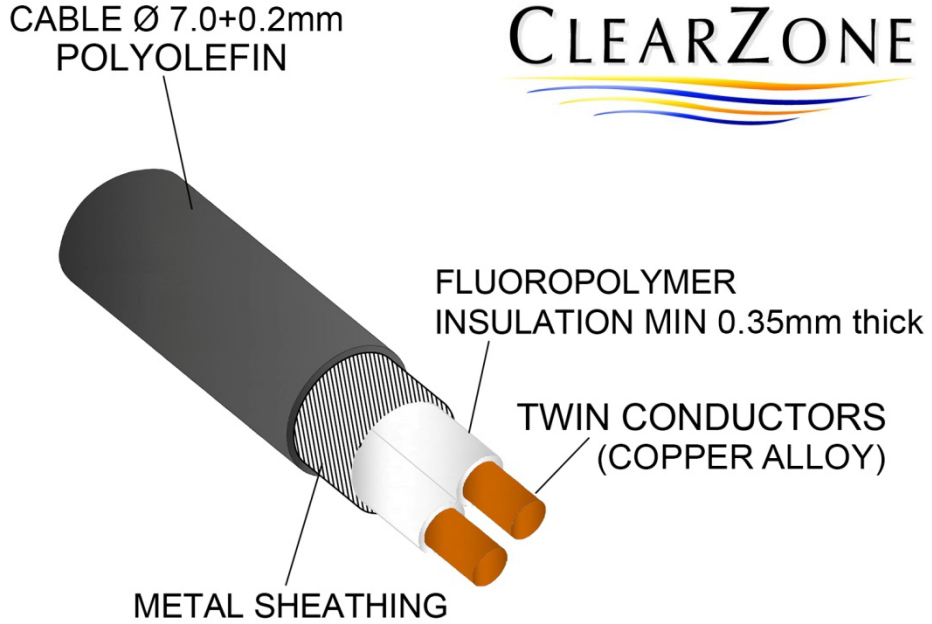

ORDERING INFORMATION

Snow Melting Cable

240 Volt (37 W and 50 W/Sq. ft.)

Item Number 240 V Cable	Length (feet)	Heated Area (50 W/Sq. ft.) 3-inch spacing	Heated Area (37 W/Sq. ft.) 4-inch spacing	Watts	Amps	Ohms
SC237450	37	9	12	450	1.9	126.3
SC262750	62	15	20	750	3.1	77.4
SC2841000	84	20	27	1,000	4.2	57.1
SC21682000	168	40	55	2,000	8.3	28.9
SC22092500	209	50	70	2,500	10.4	23.1
SC22933500	293	70	95	3,500	14.6	16.4
SC23754500	375	90	125	4,500	18.8	12.8
SC24585500	458	110	150	5,500	22.9	10.5

ORDERING INFORMATION

208 Volt (37 and 50 watts per square foot)

Item Number 208 V Cable	Length (feet)	Heated Area (50 W/Sq. ft.) 3-inch spacing	Heated Area (37 W/Sq. ft.) 4-inch spacing	Watts	Amps	Ohms
SC825300	25	6	8	300	1.4	144.2
SC843500	43	10	14	500	2.4	86.6
SC8861000	86	20	29	1,000	4.8	43.3
SC81271500	127	30	42	1,500	7.2	28.8
SC81702000	170	40	57	2,000	9.6	21.6
SC82132500	213	50	71	2,500	12.0	17.3
SC82563000	256	60	85	3,000	14.4	14.4
SC82993500	299	70	100	3,500	16.8	12.4
SC83404000	340	80	113	4,000	19.2	10.8
SC83834500	383	90	128	4,500	21.6	9.6
SC84265000	426	100	142	5,000	24.0	8.7
SC84695500	469	110	156	5,500	26.4	7.9
SC85126000	512	120	171	6,000	28.8	7.2

277 Volt (37 and 50 watts per square foot)

Item Number 277 V Cable	Length (feet)	Heated Area (50 W/Sq. ft.) 3-inch spacing	Heated Area (37 W/Sq. ft.) 4-inch spacing	Watts	Amps	Ohms
SC725300	25	6	8	300	1.1	255.8
SC743500	43	10	14	500	1.8	153.5
SC7861000	86	20	29	1,000	3.6	76.7
SC71271500	127	30	42	1,500	5.4	51.2
SC71702000	170	40	57	2,000	7.2	38.4
SC72132500	213	50	71	2,500	9.0	30.7
SC72563000	256	60	85	3,000	10.8	25.6
SC72993500	299	70	100	3,500	12.6	21.9
SC73404000	340	80	113	4,000	14.4	19.2
SC73834500	383	90	128	4,500	16.2	17.1
SC74265000	426	100	142	5,000	18.1	15.3
SC74695500	469	110	156	5,500	19.9	14.0
SC75126000	512	120	171	6,000	21.7	12.8

480 Volt

Item Number 480 V Cable	Cable Length (feet)	Heated Area (50 W/Sq. ft.) 3-inch spacing	Heated Area (37 W/Sq. ft.) 4-inch spacing	Watts	Amps	Ohms
SC443500	43	10	14	500	1.0	460.8
SC41271000	84	20	27	1,000	2.0	230.4
SC41271500	127	30	42	1,500	3.1	153.6
SC41702000	170	40	57	2,000	4.2	115.2
SC42132500	213	50	71	2,500	5.2	92.2
SC42563000	256	60	85	3,000	6.3	76.8
SC43404000	340	80	113	4,000	8.3	57.6
SC44265000	426	100	142	5,000	10.4	46.1
SC44695500	469	110	156	5,500	11.5	41.9

Special order snowmelt cable may require an additional fulfillment time of 8-10 weeks.

ORDERING INFORMATION

Activation Devices – Markers

Item	Item Number	Description	Voltage
	WS-2C	Aerial Mounted Snow Switch (30 amps) Moisture and temperature sensing	120, 240
	WS-5C	Aerial Mounted Snow Switch (60 amps) Moisture and temperature sensing	120, 240
	WS-8C	Aerial Mounted Snow Switch (30 amps) Moisture and temperature sensing Includes remote moisture sensor	120, 240
	WS-AUX	Auxiliary Control Unit for Aerial Mounted Snow Switch	120, 240
	ETO2 ETOG-56	Pavement Mounted Snow Switch and Controller Moisture and temperature sensing.	120, 240
	Warmplate	Embedded Marker Plate (NEC Required.)	n/a

ORDERING INFORMATION

Contactor Panels



Description	Max Amps	Coil Voltage	Number of Contactors
Single Contactor Panel Used to control power supply and heating cables (120 - 600 V)	50	120, 208-240	1
Dual Contactor Panel. Used to control power supply and heating cables (120 - 600 V)	100	120	2
Quad Contactor Panel. Used to control power supply and heating cables (120 - 600 V)	200	120	4
Dual Contactor Panel with GFEP. Used to control power supply and heating cables (120 - 600 V)	100	120	2
Quad Contactor Panel with GFEP. Used to control power supply and heating cables (120 - 600 V)	200	120	4

WARRANTY INFORMATION

ClearZone Cable: 10-year limited warranty.

Controls and activation devices: 2-year limited warranty.

ClearZone heat cable is CSA approved for both the U.S. and Canada.



TECHNICAL SUPPORT

For technical questions, please contact Warmzone at 888.488.WARM (9276) or via the web - www.warmzone.com.

Warmzone accepts no responsibility for possible errors in catalogs, brochures, other printed materials, and website information. Warmzone reserves the right to alter its products without notice. This also applies to products already on order provided that such alteration can be made without subsequent changes being necessary in specifications already agreed upon. All trademarks in this material are property of the respective companies. All rights reserved.